



Momcozy All-In-One M5 Wearable Breast Pump

»

Contents

- 1 Momcozy B0C99KSR96 Breast Pump Hands Free M5
- 2 Product Introduction
- 3 Warning Instruction and Precautions
- 4 Indications for Use/ Intended Use
- 5 Contraindications
- 6 Safety Information
- 7 Product Description
- 8 Operating Instructions
- 9 Storage Condition
- 10 Specification
- 11 Maintenance and Replacement Parts
- 12 Troubleshooting
- 13 Warranty
- 14 EMC Information
- 15 Travel or International Use Statement

MOMCOZY

Momcozy All-In-One M5 Wearable Breast Pump



Read this user manual carefully before using this device and keep this manual for future reference.

Product Introduction

The Momcozy Wearable Breast Pump is intended to be used by lactating women to express and collect milk from their breasts. The Momcozy Wearable Breast Pump forms a vacuum around the nipple to express breast milk. The milk is collected in a milk collector. The device includes stimulation mode, expression mode, and mixed mode. In stimulation mode, the breast pump begins with a quick and short sucking pattern to get your milk to start flowing. In expression mode, the breast pump begins with a slow sucking pattern for milk expression, sucking more deeply and more slowly. In mixed mode, the breast pump begins with a quick and short sucking pattern and then with a slow and long sucking pattern. To prevent milk from flowing into the vacuum system, the milk collection sets include a silicone diaphragm that physically separates the milk-contacting pathway from the vacuum system. The device is intended for a single user.

Warning Instruction and Precautions

The warning signs and graphic symbols in the manual are intended to enable you to use the product safely and correctly and to prevent harm to you and others. Warning marks and graphic symbols are described as follows:

Warning/precaution symbols



Warning

A warning alerts the reader about a situation that, if not avoided, could result in death or serious injury. It may also describe potential serious adverse reactions and safety hazards.



Precautions

Indicating a hazard alert that warns the reader of a potentially hazardous situation which, if not avoided, may result in minor or moderate injury to the user or patient or damage to the equipment or other property. It may also be used to alert against unsafe practices. This includes the special care necessary for the safe and effective use of the device and the care necessary to avoid damage to a device that may occur as a result of use or misuse.













Contraindications

Contraindications are conditions under which the device should not be used because the risk of use clearly outweighs any possible benefit. There may be persons for whom the device should not be used because of their health status.

Notes

Indicates the need for attention, if not attention may lead to incorrect use of the product or property device damage.

Symbol Description

	Keep Dry		Pile Limit 5 layers
	Applied part of type BF		Type of protection against electric shock: Class II
	Batch code		Refer to instruction manual.
	Manufacturer information: The manufacturer name and address		Manufacture date
	Distribution packages shall not be exposed to sunlight		Serial Number
IP22	The first number 2: Protected against solid foreign objects of 12.5mm diameter and greater. The second number 2: Protected against vertically falling water drops when enclosure tilted up to 15°.		
	Disposal in accordance with Directive 2012/19/EU (WEEE)		
	This device has not been tested for use in an MR environment and should not be used exposed to MR environments while patients are wearing the device. Keep it outside the MRI scanner room.		

Indications for Use/ Intended Use

[Indications for Use/ Intended use]

The Momcozy Wearable Breast Pump (model: M5) is intended to express milk from lactating women in order to collect milk from their breasts. ThJ device is intended for a single user.

[Intended users]

- Can read and understand the user manual
- The PATIENT is an intended OPERATOR

[Patient Population]

Lactating women

[Intended use environment]

IBome Health.care Environmerr

Contraindications

Do not use this Pump if you have an active implanted device that would be affected by a magnetic field (e.g., pacemaker; implantable cardioverter-defibrillator).

Safety Information

When using electrical products, especially if children are present, the following basic safety information should always be maintained.

Warning

1. Do not use this device if you have a cardiac pacemaker, implanted defibrillator, or other implanted metallic or electronic device. Such use could cause electrical interference or death.
2. This breast pump is not intended for use by persons (including children) with reduced physical, sensory or mental capabilities, or lack of experience and knowledge. Such persons can only use this breast pump if they are supervised by or have received proper instruction concerning the use of the appliance by a person responsible for their safety.
3. **Danger: To reduce the risk of electrocution:**
 - Always unplug electrical devices immediately after charging.
 - Do not use it while bathing, showering, driving, or swimming.
 - Do not reach for an electrical product that has fallen into the water, please unplug the power adapter from the wall outlet immediately.
4. The Momcozy Wearable Breast Pump is a personal care item and for hygienic reasons should never be shared between mothers or resold from one mother to another. Either of these actions will void the warranty.
5. If you are a mother who is infected with Hepatitis B, Hepatitis C, or Human Immunodeficiency Virus (HIV), pumping breast milk using the Momcozy Wearable Breast Pump will not reduce or remove the risk of transmitting the virus to your baby through your breast milk.
6. Close supervision is necessary when the product is used near children or invalids. Do not allow children or pets to play with the motor unit, packaging materials or accessories.
7. Use the product only for intended use as described in this manual.
8. Do not use attachments or other milk collection components other than those recommended by the manufacturer
9. Check the power adapter before charging, never use the damaged power adapter.
10. Never leave it product unattended while charging.
11. Keep the product and all attachments away from heated surfaces.
12. Never use it while sleeping or drowsy.
13. Do not operate where aerosol spray products are being used or oxygen is being administered.
14. Do not use the device around explosive or flammable material, in an MRI environment, in a hyperbaric chamber, or near a fireplace or radiant heater.
15. Avoid strangulation resulting from Charging cable.
16. Users are not allowed to repair the product. If you do so, your warranty becomes invalid. For repairs, sent to the manufacturer or a designated franchise distributor.
17. Always switch off the breast pump before you remove the pump body from your breast, in order to release the vacuum.
18. Powered breast pumps that are designed for single users should never be rented or shared.
19. Never use the breast pump while you are pregnant, as pumping can induce labor.

20. The high-level temperature of the applied part can reach a maximum of 43.9°C, excessive temperature may cause skin burns, please make sure that your skin of breast must be intact and healthy before use. If you feel overheated, please turn off the device. In order to avoid temperature burn, the maximum continuous use shall not exceed 30 minutes each time, the interval between two uses shall be at least 5min to allow the device to cool down.
21. For product service life (i.e. working life) The device has no shelf life, and the service life of the product is 500 hours. The expected operating life of the washable parts is one to three months. Please check whether the product can run normally before use. Use beyond the service life may lead to degradation of product performance. Such as, if the product cannot control the vacuum correctly, excessive vacuum may cause injuries.

Precaution

- Do not place or store where the product can fall or be pulled into the bathtub, sink, or pool.
- Do not place or drop the product into water or other liquid.
- Do not immerse in any liquid for any reason or subject the unit to extreme shocks, such as dropping the pump.
- Do not continue pumping for more than five minutes at a time if you do not succeed in expressing any milk. Try to express at another time during the day.
- If discomfort is felt, then suction can be broken by inserting a finger between the breast and the flange.
- If irritation or discomfort occurs, discontinue use and see a health care provider.
- If the power adapter casing or wiring becomes loose, separated, or frayed, stop use of the power adapter immediately and contact the device manufacturer. Stop using the device immediately if you note any smoke or burning from the pump unit or power adapter.

Statement:

If you feel excessive warmth from the Wearable breast pump while pumping, stop pumping immediately and remove pump.

Notes:

Avoid direct sunlight to the main unit.

Product Description

The product is mainly composed of main unit and milk collection set etc.

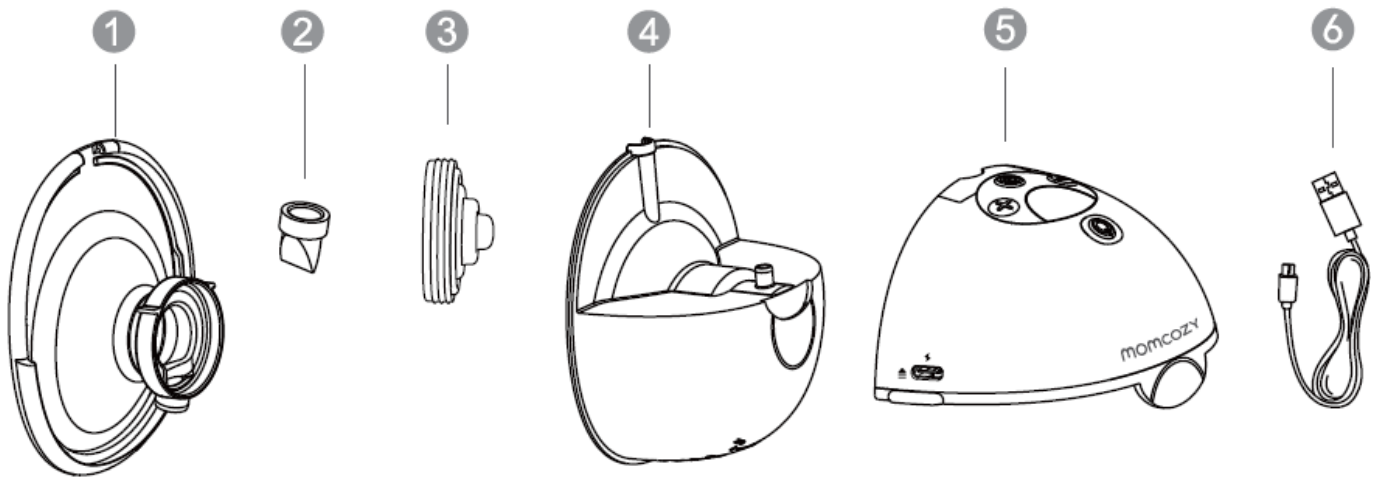

Fig.1 unit description

NO.	Item	Description
①	24mm Double-sealed Flange	All of these components make up the milk collection set
②	Valve	
③	Diaphragm	
④	Milk collector (160ml)	
⑤	Main unit	Pump motor
⑥	USB Type-C cable	Input end is USB 2.0 interface, the output end is Type-C interface

Other Accessories Included:

- 17mm flange insert
- 19mm flange insert
- 21mm flange insert
- 24mm Double-sealed flange
- Quick start guide
- Flange cover
- Flange size ruler
- Storage box
- User manual

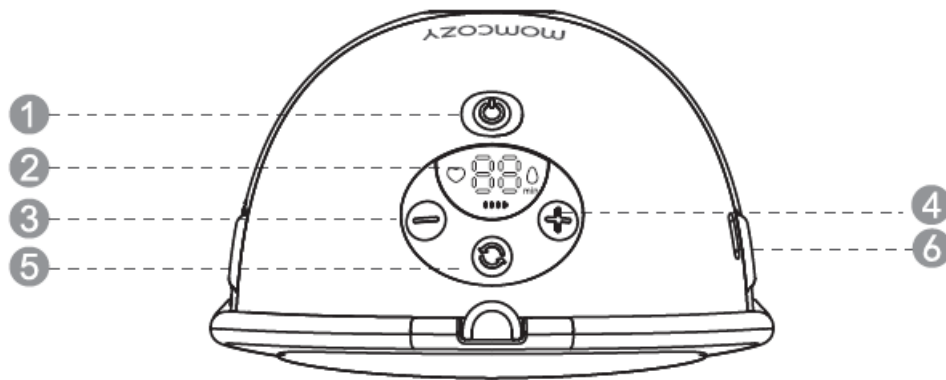













Fig.2 control panel

1. On / Off / Pause
2. LED Display
3. Decrease
4. Increase
5. Mode Selection
6. Charging Port

No.	Buttons and LEDs	Functions
1		Long press and hold to turn on / off; Short press to pause, then press any button to continue your pumping session.
2		Mode selection
3		Decrease suction strength
4		Increase suction strength
5		Stimulation Mode: In this mode, the breast pump begins with a quick and short sucking pattern to get your milk to start flowing.
6		Expression Mode: The breast pump begins with a slow sucking pattern for milk expression, sucking more deeply and more slowly.
7		Mixed Mode: In this mode, the breast pump begins with a quick and short sucking pattern followed by a slow and long sucking pattern.
8		Suction Level Display: The breast pump has 9 suction levels to choose from. Running Time Display: 00-29min (the pump will shut off automatically after 30 minutes.)
Battery Level Indicator		
Low Battery: Blinking	In Charging: Lights up one by one	Fully Charged: Stays on solid
		

Operating Instructions

Charging battery

Please charge the product before using it for the first time. The breast pump is powered using an internal rechargeable lithium battery.

Our products are packaged with a Charging cable (USB2.0/Type-C line) but not with a power adapter. Please purchase the power adapter by yourself before charging. Make sure to buy the power adapter which matches the USB 2.0 interface, and please make sure the input power of the power adapter is AC 100~240V 50/60 Hz and the output power is DC 5V 1A.

- When the first battery indicator bar flashes, it means the battery is low, and there are 30 minutes of use time left. Please charge the device in time.

- After being fully charged, it can be used for 4-5 sessions (about 150 minutes) of pumping, 30 minutes per session.

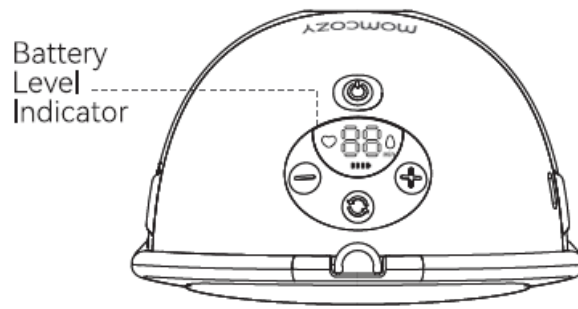

Fig. 3

Charge the battery as below:

- Insert the USB end of the Charging cable into the USB interface of power adapter;
- Insert power adapter plug into AC socket;
- Insert the Type-C end of the Charging cable into the charging port.

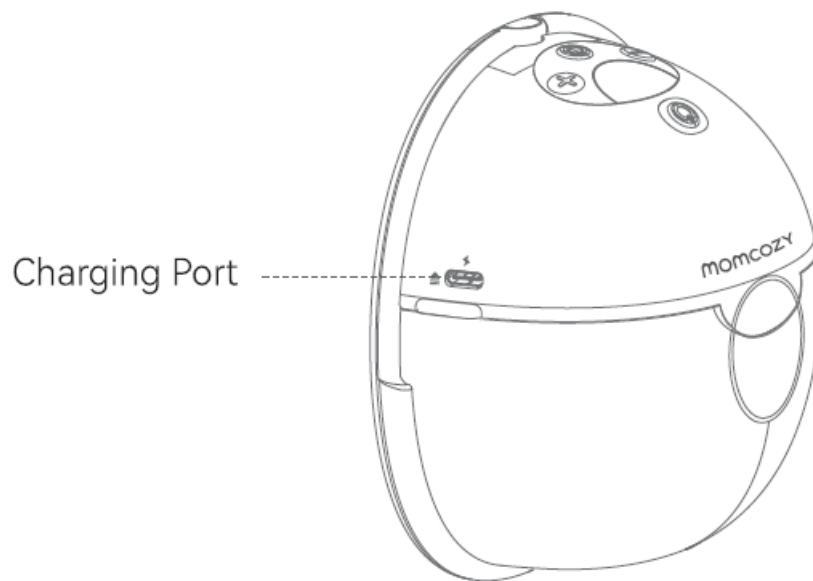
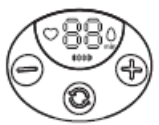



Fig. 4 Position of Charging port

The device will take approximately 120 minutes to fully charge Charging

Battery Level Indicator		
Low Battery: Blinking	In Charging: Lights up one by one	Fully Charged: Stays on solid
		

Unplug the power adapter from the socket, and disconnect the Charging cable from the power adapter and main unit after charging is completed.

Warning

- The breast pump cannot be used during charging!
- The Charging cable is only used to connect between the power adapter and the Momcozy Wearable Breast Pump unit for charging, please do not connect to other equipment, otherwise, it may cause an electric shock accident!

If the power adapter casing becomes loose, separated, or frayed, stop the use of the power adapter immediately and contact the manufacturer of the power adapter.

- If the Charging cable is damaged, broken or cracked, stop the use of the Charging cable immediately and contact the manufacturer to replace a new one (See the last page of this manual for contact information).
- Stop using the device immediately if you note any smoke or burning from the pump unit or power adapter.

Caution:

Using the wrong type of adapter or purchasing a poor-quality adapter may reduce the device's safety, and may damage your property and health. Please purchase the medical adapter that meets the IC 60601-1 and IEC 60601-1-2 standards in professional medical markets, and make sure the output of the power adapter is DC 5V 1A.

Notes:

- After fully charging the battery, if the working time of the battery is shorter than before and you want to replace it, don't try to replace the rechargeable battery by yourself. Please contact the manufacturer for replacement. Self-disassembly and replacement of the battery may cause damage to the main unit and battery.
- When the product is not used for a long time, the battery will discharge slowly. In order to avoid battery damage due to low voltage for a long time, please charge the device every three months.

Cleaning and disinfection

General description/requirement

Providing breast milk is one of the best things you can do for your baby's health and development. Pumping your milk is one way to provide breast milk to your baby. Keeping the parts of your pump clean is critical because germs can grow quickly in breast milk or breast milk residue that remains on pump parts. Following these steps can help prevent contamination and protect your baby from infection. If your baby was born prematurely or has other health concerns, your baby's health care providers may have more recommendations for pumping breast milk safely.

1. BEFORE EVERY USE

- Inspect and assemble a clean pump kit.
- Clean pump motor with disinfectant wipes.

2. AFTER EVERY USE

Store milk safely: Use breast milk storage bags or clean, food-grade containers to store expressed breast milk. Make sure the containers are made of glass or plastic and have tight-fitting lids, and label them with the date and time, and immediately place them in a refrigerator, freezer, or cooler bag with ice packs. Clean pumping area: Clean the dials, power switch, and countertop with disinfectant wipes.

3. Parts that need to be cleaned and disinfected Clean and disinfect all parts that come into contact with breast

and breast milk before you use the breast pump for the first time and after every use.

- Milk contact part: parts of milk collection set, including Flange, Linker, Diaphragm, Valve, and Milk Collector.
- Parts that only contact the breast skin: Flange.

4. Before cleaning/disinfection:

- Please Wash your hands well with soap and water for 20 seconds.
- Please disassemble all the parts as follows:

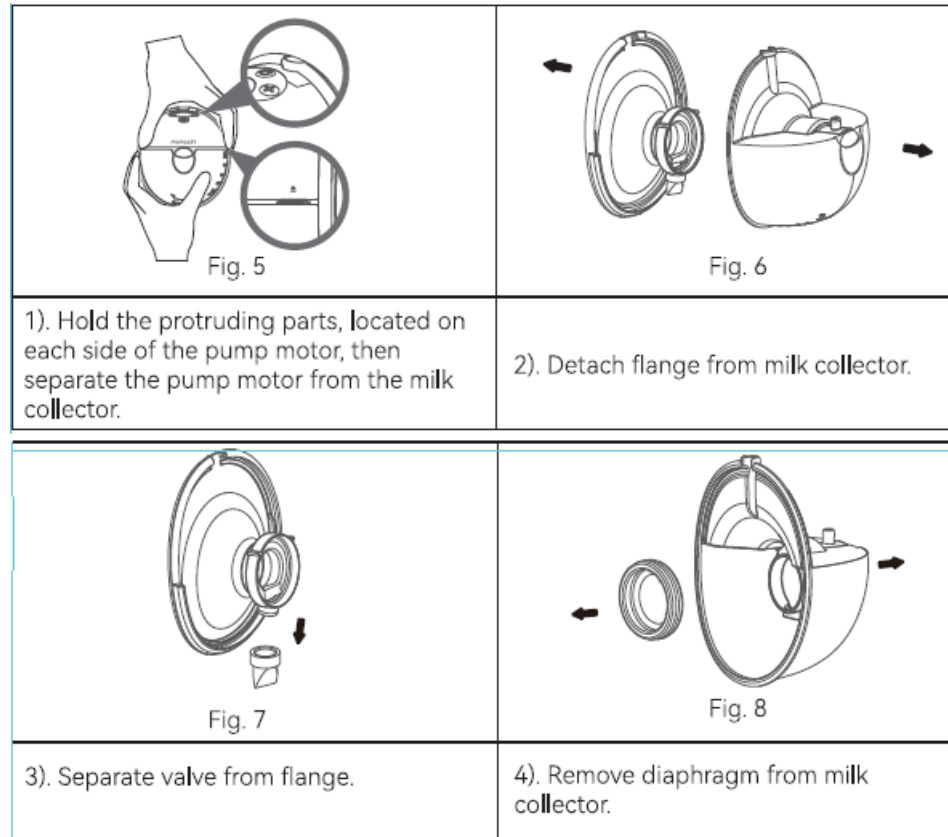

Caution:

Never put the main unit, charging cable or the adapter (If you have purchased an adapter) in water or a dishwasher, as this causes permanent damage to these parts.

Cleaning and disinfecting parts contacting with the milk

Step 1: Cleaning

Please manually clean the device! The safety of using a dishwasher to clean and disinfect this product has not been verified.

Warning

Do not use antibacterial or abrasive cleaning agents to clean the breast pump parts as this may cause damage.

1. Prepare the below items:

- Soap and hot water
- Drinking-quality water
- Clean wash basin used only for infant feeding items
- Clean brush used only for infant feeding items
- Unused dish towel or paper towel

2. **Rinse:** Rinse parts of milk collection set and any other feeding items by holding them under running water to

remove the remaining milk or dirt. The water can be warm or cold, whatever you prefer.

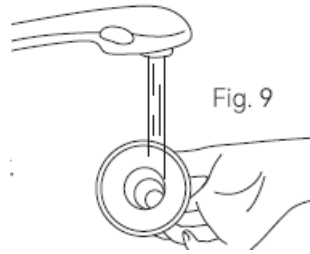

3. Wash milk collection parts:

- Place parts of the milk collection set in a clean wash basin used only for infant feeding items. Do not wash directly in the sink because it may contain germs that could contaminate these items.
- Soak parts of the milk collection set in warm 40-60 °C (104-140 °F), soapy water for 3~5 minutes.

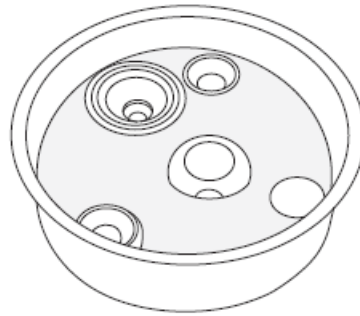

Fig. 10

- Using a clean brush used only for infant feeding items to scrub items.
4. **Rinse again:** Rinse by holding items under running water, or by submerging them in fresh water in a separate basin that is used only for cleaning infant feeding items. If there is still dirt, repeat step 3 and re-rinse until there is no visible dirt.
5. **Air-dry thoroughly:** Place parts of the milk collection set, wash basin, and bottle brush on a clean, unused dish towel or paper towel in an area protected from dirt and dust. Do not use a dish towel to rub or pat items dry because doing so may transfer germs to the items!

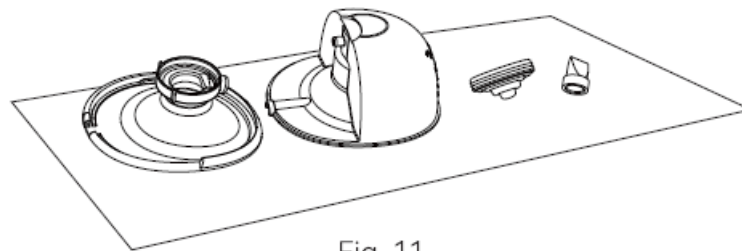

Fig. 11

6. Clean wash basin and bottle brush: Rinse the wash basins and brush well and allow them to air-dry after each use. Wash them every few days by hand with soap and warm water. If your baby is less than 3 months old, was born prematurely, or has a weakened immune system due to illness (such as HIV) or medical treatment (such as chemotherapy for cancer), wash basin and bottle brush after every use.

After Cleaning:

For extra germ removal, disinfect the parts of milk collection set, wash basin, and bottle brush at least once daily after they have been cleaned. Items can be disinfected using boiling water with a disinfection setting. Disinfection is especially important if your baby is less than 3 months old, was born prematurely, or has a weakened immune system due to illness or medical treatment. For the disinfection of milk contact parts, please refer to step 2.

Step 2: Disinfection

Caution: Do not sterilize pump parts in a microwave or UV sterilizer. High temperature(> 110 °C) will shorten their service life and cause

safety hazards.

Before disinfection, make sure you have a cleaned milk collection set, bottle brushes, and wash basins using the methods above. Disinfect all items in contact with milk (even the bottle brush and wash basin!) by using one of the following methods.

1. Prepare the below items:

- A household pot
- Drinking-quality water
- Clean tongs

Caution:

During disinfection with boiling water, prevent the bottle or other parts from touching the sides of the pot.

This can cause irreversible product deformation or damage.

2. Place the disassembled milk collection set in the pot and fill the pot with enough water to cover the components to disinfect. Let the water boil for 5-10 minutes, making sure the parts do not touch the sides of the pot.

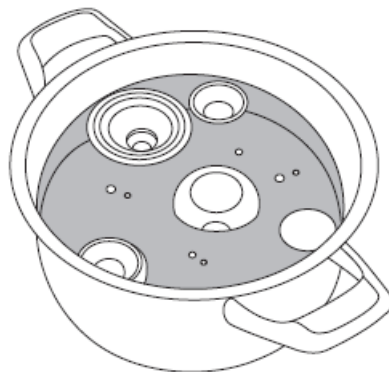

Fig. 12

3. Remove items with clean tongs.



Fig. 13

4. Air-dry thoroughly.

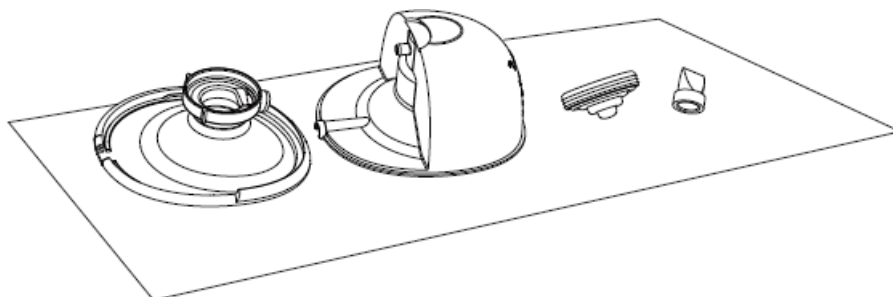

Fig. 14

Step 3: Store safely

Store dry items safely until needed. Ensure the clean pump parts, bottle brushes, and wash basins have air-dried thoroughly before storing. Items must be completely dry to help prevent germs and mold from growing. Store dry items in a clean, protected area to prevent contamination.

1. **Wash hands:** Wash hands well with soap and water.
2. **Put back together:** Put together the clean, dry pump parts.
3. **Store safely:** Place reassembled pump parts and other feeding items wash basin, and dry bottle brush in a clean, protected area such as inside a closed kitchen cabinet that is used only to store clean dishes.

Clean / Disinfect the other parts

The shell of the main unit need to be cleaned and disinfected for the first time and after each use. The other parts, do not come into contact with the human body nor the milk during pumping, and only need to be cleaned when it is dirty. Cleaning/disinfecting the items at room temperature 5 °C~ 40 °C as below:

Prepare the below items:

- Disinfection
- 70% isopropyl alcohol wipes
- Clean soft cloth

Cleaning method:

1. Before performing this cleaning procedure, wash your hands with hand disinfection first.
2. Remove all residual foreign matter from the main unit and/or Charging cable using a clean soft cloth.
3. Take a piece of 70% isopropyl alcohol wipes to swab on the parts until no visible contaminants remain.
4. Dry the device by placing it at room temperature for 10min to evaporate the residual cleaning reagent solution on the product.

Disinfection method:

Cleaning the shell of the main unit as the above method before disinfection.

1. Disinfect the shell of the main unit with a soft cloth dampened with the 70% isopropanol for 3 minutes.
2. Dry it by placing the main unit at room temperature for 10min to evaporate the residual disinfection solution.

Direction for use

Preparation before use

Caution:

- Wash hands with soap and water, and inspect and assemble a clean pump kit.
- **Duration of pumping session:**

This product is powered by a rechargeable lithium battery, after being fully charged, it can be used for 4-5 sessions (about 150 minutes) of pumping, 30 minutes per session. A typical pumping session lasts about 10-15 minutes per breast, but you should only pump as long as it is comfortable and productive for you

1. Select Flange Size

This Momcozy Wearable Breast Pump only provides one 24mm silicone flange. If the flange provided does not fit, you can find various flanges and flange inserts available for purchase on Amazon. Type “momcozy” in the search bar and find the flange size and flange insert that fits you.

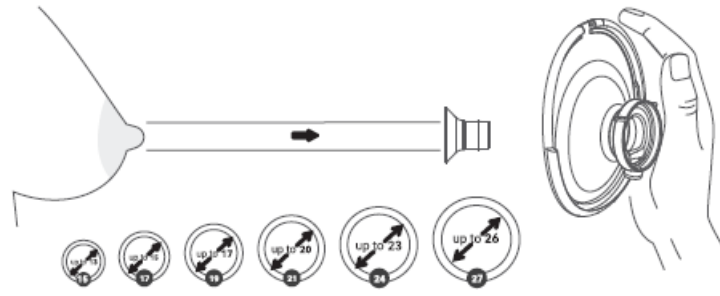

Fig.15 select right size

2. Stimulate the Nipple

- Stimulate your nipple to get a full size (do not skip this step!).
- Place the nipple into the smallest hole you can comfortably fit into without forcing it.
- Select the hole that can comfortably fit the very base of your nipple.
- Get your measurement based on the sizing chart.

3. Test the Flange Fit

- To find the suitable size flange, first, you need to make sure you place the flange in the right place on your breast.
- Please press the flange on your breast until there is no gap. Make sure your nipple is right in the middle of the flange.

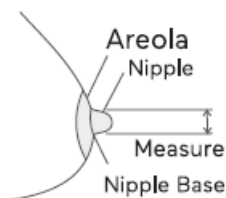

Fig.16



Fig.17

Too small: During pumping, if your nipple continues to rub against the inner wall of the flange, then this flange is too small for you.

Too large: During pumping, if a large area of areola is sucked inside, then this flange is too big for you.

4. Get the Right Bra

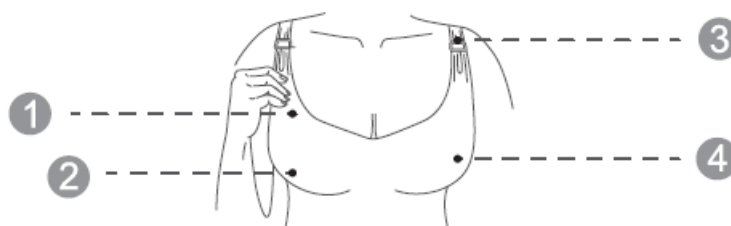
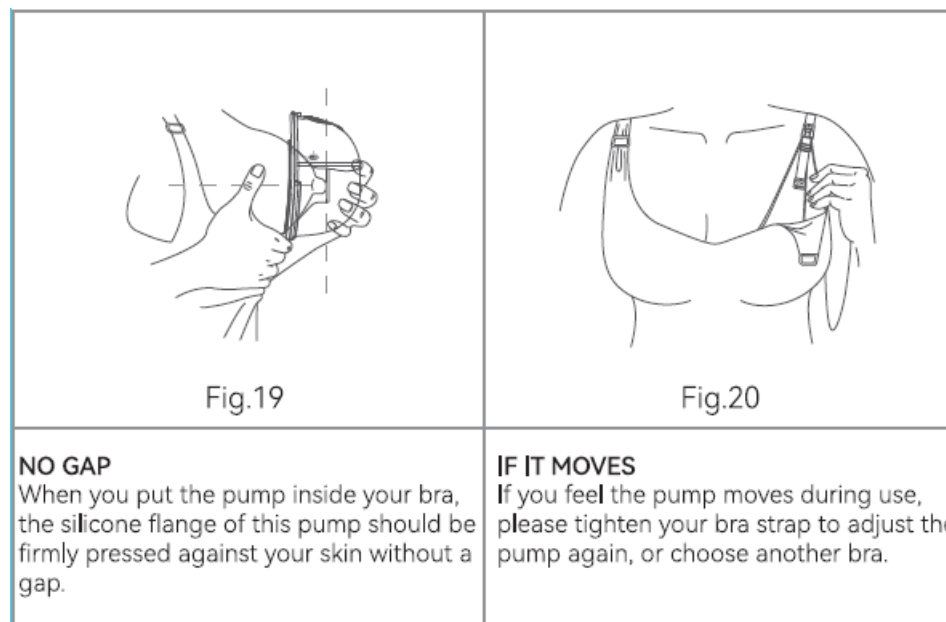

Fig.18

1. Made of stretchy fabric
2. No underwire or padding
3. Has a flap

4. Full coverage



5. Recommend Posture

Caution:

Always sit or stand upright while pumping to prevent the milk from leaking. This pump is not to be used when lying down or sleeping to ensure the proper orientation is maintained during use.

POSTURE

Make sure the pump and the milk collector always stay at a vertical angle. Otherwise, the milk will spill out.



Fig.21 right posture

Assembling the Pump

Caution:

Make sure you have cleaned and disinfected the parts of the breast pump that come into contact with milk or breast.



Warning

- Be careful, when you have disinfected the breast pump parts by boiling them, they can be very hot. To prevent burns, only start assembling the breast pump when disinfected parts have cooled down.
- Wash your hands thoroughly with soap and water before you touch breast pump parts and breasts to prevent contamination. Avoid touching the inside of milk collection set.

Notes:

- Correct placement of the Double-sealed Flange, Diaphragm, Milk collector, Valve, etc. is essential for the breast pump to form a proper vacuum.
- Before each use visually inspect the individual components for cracks, chips, tears, discoloration, or deterioration. In the event that damage to the device is observed, please discontinue use until the parts have been replaced.

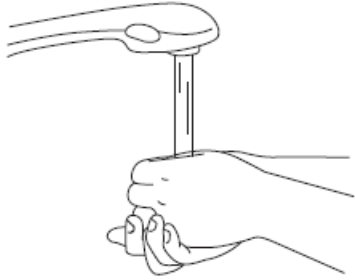
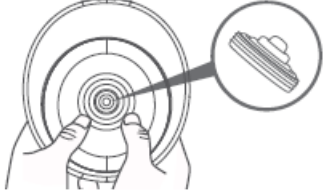
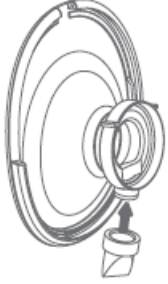
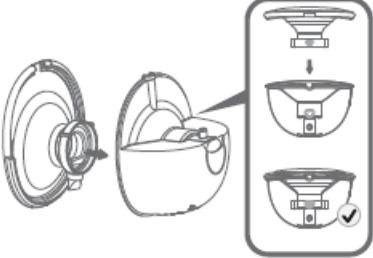
Wash your hands thoroughly with soap and water, then assemble the pump as follows:

 <p>Fig. 22</p>	 <p>Fig. 23</p>
<p>1. Wash your hands thoroughly with soap and water.</p>	<p>2. Attach the diaphragm with the milk collector and apply mild pressure around the edge until the diaphragm seals well with the milk collector.</p>
 <p>Fig. 24</p>	 <p>Fig. 25</p>
<p>3. Gently push the valve into the flange. Make sure there are no gaps.</p>	<p>4. As shown in the picture, align the flange with the milk collector and the two patterns should overlap. Make sure the flange fits securely around the rim by pressing it down with your thumbs.</p>
 <p>Fig. 26</p>	
<p>5. Assemble the pump motor and milk collector.</p>	

The breast pump is now ready for use.

7.3.3 Pumping instructions

Warning

- Before you remove the pump body from your breast, always switch off the breast pump to release the vacuum.
- Do not continue pumping for more than 5 minutes at a time if you do not succeed in expressing any milk. Try to express at another time during the day.
- If the process becomes very uncomfortable or painful, stop using the pump and consult your healthcare professional.

Caution:

- Monitoring milk level during pumping to ensure overfill does not occur.

1. Alignment

- Before pumping, please make sure the pump is pressed tightly on your breast without a gap (Fig.27).



Fig. 27

- To align, hold the flange against your breast so you can see if your nipple is centered in the flange tunnel. You may need to bend forward.
- After you've aligned, look through the flange to confirm your nipple is centered before pumping. The tip of your nipple should NOT touch the top, sides or bottom of the flange tunnel. If it does, try again.

First Perspective

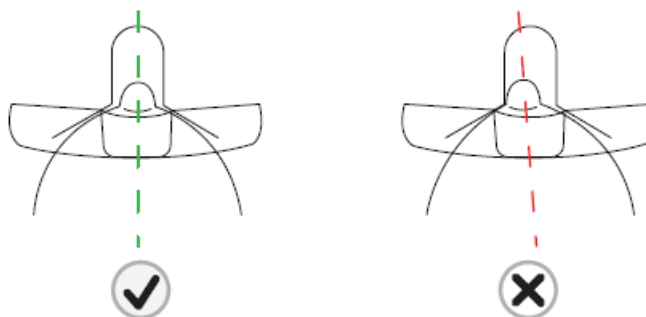

Note:

Correct nipple alignment is key to comfort expression and performance. Nipple must be positioned correctly in flange tunnel before pumping to avoid discomfort. See Section 7.3.1 Preparation before use- Select Flange Size.

2. Secure Pump In Bra

Secure Pump in place by bra, taking care to keep Pump pressed firmly against breast. If necessary, tighten bra to keep pump securely in place and start pumping.

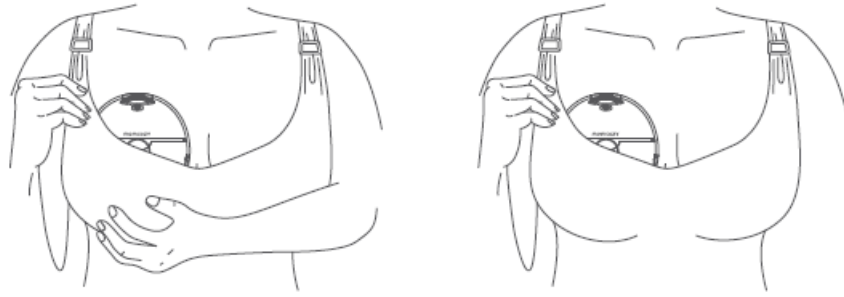

Fig. 29

3. Start Pumping

Do not slide the pump directly into your bra, follow step-by-step instructions. Disconnect from Charger before use.

- **Turn on the pump**

Consult your health care practitioner to understand how long you should pump. Momcozy pump shuts off automatically after 30 minutes of pumping time.

Long press the On / Off / Pause button to turn on or turn off the pump. Short press the On / Off / Pause button to pause, then press any button to continue your pumping session.

- The default mode is Mixed mode when you first use the pump
- The default vacuum level is level 1 (at this time, the suction level LED display 1 as level 1).

- **Select the mode**

- **Modes:** Stimulation Mode & Expression Mode & Mixed Mode When you first use the pump, the default setting is suction level 1 of Mixed mode.
- **Memory function:** The pump will remember and start with the previous suction level of mixed mode when you use it next time. Short press the Mode Selection button to switch from 3 modes.

- **Select the vacuum level**

Momcozy pump has 9 vacuum pressure settings for each mode, giving you control over what feels comfortable and works most efficiently in all modes.

Once you can feel the vacuum pressure on your nipple, use the Increase/Decrease button to adjust the vacuum pressure to find your preferred setting in all modes. The LED display will be off after no operation for 20 seconds, press any button can activate the LED display again.

Tip: A higher vacuum pressure does not always mean a higher volume of milk. Putting your nipple under excess stress can reduce milk production. Always ensure you are pumping at a comfortable level. If you don't feel suction, please check the pump is assembled correctly.

Caution:

- Momcozy pump does not support use while charging. Always disconnect from the charger and close the charging cap before use.
- Momcozy pump should not be used while lying down, engaging in strenuous activities or performing activities with risk of harm.
- Using a breast pump should not cause pain. Do not try to express with a vacuum pressure setting that is too high or uncomfortable.
- If excessive discomfort or pain is felt during pumping, stop pumping, break the seal around your nipple and discontinue the session.

4. Pause / Start Pumping

To pause while pumping, short press the On / Off / Pause button and the mode indicator will be blinking. Press any button to continue your pumping session.

5. Turn off the Pump

Long press the On / Off / Pause button for 2 seconds to turn off the pump. In addition, the product will automatically shut down after the 30min of pumping time.

- **Remark:** Pause/start pumping, mode and vacuum level selection will not reset the pumping time.

6. Remove the Pump

Use your finger to break the seal between the flange and the breast tissue. Lean slightly forward to remove the pump from the breast after your pumping session, then keep the flange opening side up to prevent milk from pouring over.



Fig. 30

We recommend the user stop the pumping session once the expressed milk volume of the milk collector approaches 120 ml to avoid overflow. After finishing the milk collection, please pour the newly expressed milk into other milk collectors with caps or milk storage bags in time. Screw the cap tightly onto the other Milk collector and store the milk.

Warning

- The Milk collectors provided are for collecting the milk during suction. If you need to feed the baby or store the expressed breast milk, please use another Milk collector with a cap.
- Refrigerate or freeze expressed milk immediately or keep it at a temperature of 16 °C~ 25 °C for 2-4 hours before you feed your baby.

Storing breast milk

Proper storage of breast milk

Following recommended storage and preparation techniques can maintain the safety and quality of expressed breast milk for the baby's health. These are general guidelines for storing human milk at different temperatures. Various factors affect how long human milk can be stored safely. Such factors include milk volume, room temperature when milk is expressed, temperature fluctuations in the refrigerator and freezer, and cleanliness of the environment.

Storing breast milk after expressing:

- Refrigerate or chill milk right after it is pumped, if possible. You can put it in the refrigerator, place it in a cooler or insulated cooler pack, or freeze it in small (2 to 4 ounce) batches for later feedings.
- Use breast milk storage bags or clean, food-grade containers to store expressed breast milk. Make sure the containers are made of glass or plastic and have tight-fitting lids.
 - Avoid bottles with the recycle symbol number 7, which indicates that the container may be made of BPA-containing plastic.

- Remove air before sealing.
- Lay bags flat to freeze. To prevent sticking between bags, please separate the bags with paper towels.
- Never store breast milk in disposable bottle liners or plastic bags that are not intended for storing breast milk.
- Gently swirl the container to mix the cream part of the breast milk that may rise to the top back into the rest of the milk. Do not shake the milk. This can make some of the milk's valuable parts break down.
- Freshly expressed or pumped milk can be stored:

Type of Breast Milk	Storage Locations and Temperatures		
	Countertop 77 °F (25°C) or colder (room temperature)	Refrigerator 40 °F (4°C)	Freezer 23 °F (-5°C) or colder
Freshly Expressed or Pumped	Within 2–4 hours	Within 24 hours	Within 3 months
Thawed, Previously Frozen	Use within 2 hours after the baby is finished feeding		

These guidelines are for healthy full-term babies only and may vary for premature or sick babies. Check with your health care provider.

Storage tips:

- Clearly label on the storage container with the date it was expressed, include your child's name if you are giving the milk to a childcare provider.
- Do not store breast milk in the door of the refrigerator or freezer. This will help protect the breast milk from temperature changes from the door opening and closing.
- If you don't think you will use freshly expressed breast milk within 4 days, freeze it right away. This will help to protect the quality of the breast milk.
- When freezing breast milk:
- Store small amounts to avoid wasting milk that might not be finished. Store in 2 to 4 ounces or the amount offered at one feeding.
- Leave about one inch of space at the top of the container because breast milk expands as it freezes.
- Breast milk can be stored in an insulated cooler with frozen ice packs for up to 24 hours when you are traveling. At your destination, use the milk right away, store it in the refrigerator, or freeze it.

Safe thawing of breast milk

- Always thaw the oldest breast milk first. Remember first in, first out. Over time, the quality of breast milk can decrease.
- There are several ways to thaw your breast milk:
- In the refrigerator overnight.
- Set in a container of warm or lukewarm water.
- Under lukewarm running water.
- Never thaw or heat breast milk in a microwave. Microwaving can destroy nutrients in breast milk and create hot spots, which can burn a baby's mouth.
- If you thaw breast milk in the refrigerator, use it within 24 hours. Start counting the 24 hours when the breast

milk is completely thawed, not from the time when you took it out of the freezer.

- Once breast milk is brought to room temperature or warmed, use it within 2 hours.
- Never refreeze breast milk after it has thawed.

Storage Condition

How to store the pump

- Short-term storage
- Please keep the breast pump out of direct sunlight. Store the breast pump and its accessories in a safe, clean, and dry place, and away from children.
- **Long-term storage**
First, please charge the pump before long-term storage in which way the service life of this pump can be prolonged. Second, keep it in a place away from direct sunlight in avoidance of discoloration. Third, clean and dry the washable parts before storing them.
- **Temperature:** -20 to 60 °C/ -4 to 140 °F
- **Relative Humidity:** 15% – 90%
- **Ambient Pressure:** 90 to 106 kPa

Specification

Model No.	M5
Name	Momcozy wearable breast pump
Power requirements	Input: 100-240Vac, 50/60Hz; Output: 5V 1A (Charge through provided USB 2.0/Type-C Charging cable and self-purchased power adapter)
Power supply	DC 3.7 V / 1300mAh Rechargeable lithium battery
Rated power	5W
Pump options	Single pump
Suction modes	Stimulation Mode, Expression Mode, and Mixed mode
Vacuum range	Stimulation mode: -52 to -113 (±5) mmHg Expression mode: -105 to -240 (±5) mmHg Mix mode: -52 to -240 (±5) mmHg

Cycle speed	Stimulation mode: 50~120(±2) cycle/min Expression mode: 23~57(±2) cycle/min Mixed mode: 6~16(±2) cycle/min
Pump dimension	128mm X 117mm X 74mm
Weight(with all accessories)	230g
Product use life	500 hours
Noise level	≤50dB
Type of protection against electric shock	Internally powered equipment
Degree of protection against electric shock	Type BF applied part (milk collection set)
Operating conditions	Temperature: 0°C to 40°C; Humidity: 15% to 90%, Atmospheric Pressure: 70 kPa to 106 kPa
Transportation & Storage environment	Temperature: -20 °C to 60 °C; Humidity: 15% to 90%, Atmospheric Pressure: 70 kPa to 106 kPa
Battery charging time	120 minutes
Battery usage Time	150 minutes

Maintenance and Replacement Parts

The device contains no user serviceable parts inside: Opening or tampering with this device will void the warranty. In the event the device requires repair, it should be returned to the medical equipment company or to retailer directly. Modification of any kind is prohibited. The MANUFACTURER will make available on request circuit diagrams, component part lists, descriptions, calibration instructions, or other information that will assist SERVICE PERSONNEL to repair those parts of the device that are designated by the MANUFACTURER as repairable by the SERVICE PERSONNEL. When the product is not used for a long time, the battery will discharge slowly. In order to avoid battery damage due to low voltage for a long time, please charge the device every three months.

Warning

- **Warning:** the replacement of lithium batteries by inadequately trained personnel could result in a hazard.
- Do not clean or maintain the device while the device is in use or while charging.

Declaration of Conformity

Shenzhen Lutejiacheng Technology Co., Ltd. declares that the device conforms to the following standards IEC60601-1, IEC60601-1-2, JEC60601-1-11, IEC62304, ISO10993-5, ISO10993-10, ISO10993-1, ISO 14971.

Troubleshooting

Problems	Solutions
Pump does not work	<ul style="list-style-type: none"> • If the let-down has not yet occurred, consider leaving the pump on breast for a longer period of time to observe for possible delayed let-down. Note: Initial milk let-down time is unique for each person and varies by many factors. • Check nipple alignment, pause the pump, and remove it from the breast. Realign the pump as described below. • You may not have the correct Flange size (Refer to Section 7.3 Direction for Use - Select Flange Size).
Milk does not flow	<ul style="list-style-type: none"> • Pause the pump and remove it from breast. Realign it correctly. (Refer to Section 7.3 Direction for Use - Alignment). • You may also separate the pump from the flange to realign . Then, center your nipple in the flange tunnel and bring the pump to your breast (Refer to Section 7.3 Direction for Use - Alignment).
Need to realign	<ul style="list-style-type: none"> • Pause the pump and remove it from breast. Realign it correctly. (Refer to Section 7.3 Direction for Use - Alignment). • You may also separate the Pump from the Flange to realign. Then, center your nipple in the flange tunnel and bring the pump to your breast (Refer to Section 7.3 Direction for Use - Alignment).

Feel discomfort while pumping	<ul style="list-style-type: none"> • If you're experiencing excessive discomfort, please try the following (Refer to Section 7.3 Direction for Use - Alignment): <ul style="list-style-type: none"> • Make sure to press the Momcozy pump firmly against breast during Stimulation phase. • Tighten the bra to make sure the Momcozy pump is held firmly against the breast. • Decrease suction strength. • Realign the Momcozy pump. • You may be pumping for too long. Momcozy pump shuts off automatically after 30 minutes. • You may not have the correct flange size(Refer to Section 7.3 Direction for Use - Select Flange Size). <p>Stop and see a medical professional or breastfeeding specialist.</p>
Decreased (low) pump suction	<ul style="list-style-type: none"> • The Pump has 9 suction settings. Press the increase button to increase suction strength. • Check the condition of your washable parts. They should be replaced after three months of use. • If that does not work, try the following: <ol style="list-style-type: none"> 1. Check connections between all washable parts to ensure all are secure. 2. Visually inspect all washable parts and replace them if damaged. 3. Check that power is on. 4. Press the Pump securely against the breast.
Stop pumping	<ul style="list-style-type: none"> • Pump stops pumping automatically after 30 minutes. • Short press On / Off / Pause button will pause the pump, press again will resume.
Pump does not stop pumping	<ul style="list-style-type: none"> • Press the On / Off / Pause button. • If the issue persists, then break the seal by inserting a finger between the breast tissue and the flange. Then Press the On / Off / Pause button to turn the pump off.
Pump or Charger gets wet (immersed in water).	<ul style="list-style-type: none"> • Dry the pump off immediately. Prop Pump upright with the charger port down and suction controls up, and let it air dry overnight. Do not use the pump or charger within 24 hours. • Contact Customer Care.
Pump is not charging.	<ul style="list-style-type: none"> • Ensure the USB Type-C cable with standard Charger (not included) is fully plugged into the pump charging port.

Disposal

At the end of the product life cycle, do not throw this product into the normal household garbage, but bring it to a collection point for the recycling of electronic equipment and battery. Waste Electrical and Electronic Equipment may have potentially harmful effects on the environment. Improper disposal may lead to the accumulation of harmful toxins in the air, water, and soil, which is harmful to human health. you have obligation to dispose of the device correctly. Consult your municipal authority for information about disposal.

Warranty

Please contact the manufacturer in case of a claim under the warranty, the contact information please refer to last page of this user manual. If you have to send the unit, enclose a copy of your receipt with clear statement of defect description.

The warranty terms are as below:

1. The warranty period for the device is one year from the date of purchase. In case of a warranty claim, the date of purchase has to be proven by means of the sales receipt or invoice.
2. Repairs under warranty do not extend the warranty period either for the device or for the replacement parts.
3. The following cases are excluded under the warranty
 - All damages which are arisen due to improper treatment, e.g. non-observance of the user instruction.
 - All damages which are arisen due to repairs or tampering by the customer or unauthorized third parties.
 - Damages which are arisen during transport from the manufacturer to the consumer or during transport to the service center.
 - Accessories which are subject to normal wear and tear.
 - Device damage due to privately disassemble devices.
 - Liability for direct or indirect consequential losses caused by the unit is excluded even if the damage to the unit is accepted as a warranty claim

EMC Information

The equipment with following ESSENTIAL PERFORMANCE is intended used in Home healthcare environment facility environment.

Essential Performance:

Device-Specific Function	Device-Specific Pass/Fail Criteria	Detection/Testing Method
Vacuum strength (error: $\pm 5\text{mmHg}$)	Suction levels (stimulation): -52mmHg to -113mmHg Suction levels (Expression): -105mmHg to -240mmHg Suction levels (Mix): -52mmHg to -240mmHg	Vacuum manometer Observation
Cycle speed (cycles/min) (error: $\pm 2\text{cycles/min}$)	Suction levels (stimulation): 50-120 Suction levels (Expression): 23-57 Suction levels (Mix): 6~16	Observation
Maximum vacuum	-290mmHg	Vacuum manometer Observation
Software for suction pressure regulation	-290mmHg	Vacuum manometer Observation
Backflow prevention mechanism	No leakage at maximum vacuum	Observation

If Essential Performance is lost or degraded due to electromagnetic disturbances, this may result in loss of product function or injury to patients. please read below important information before to avoid possible electromagnetic disturbances.

Warning

- Using cell phone or microwave oven, HF surgical equipment, magnetic resonance imaging or other radio radiant equipment near this product may cause malfunction.
- Use of this equipment adjacent to or stacked with other equipment should be avoided because it could result in improper operation. If such use is necessary, this equipment and the other equipment should be observed to verify that they are operating normally.
- Portable RF communications equipment (including peripherals such as antenna cables and external antennas) should be used no closer than 30 cm (12 inches) to any part of the Momcozy Wearable Breast Pump, including cables specified by the manufacturer. Otherwise, degradation of the performance of this equipment could result.
- Use of accessories, transducers and cables other than those specified or provided by the manufacturer of this equipment could result in increased electromagnetic emissions or decreased electromagnetic immunity of this equipment and result in improper operation.

Caution:

- Security, antitheft, and radiofrequency identification (RFID) devices. Some electromagnetic anti- theft systems and metal detectors such as those used at entrances or exits of department stores, libraries, and other public places, and airport security screening devices may affect the Momcozy Wearable Breast Pump. Please do not use Momcozy Wearable Breast Pump near these places. Additionally, RFID devices, which are often used to read identification badges, as well as some tag deactivation devices, such as those used at payment counters at stores and loan desks at libraries, may also affect the Momcozy Wearable Breast Pump. Please do not use Momcozy Wearable Breast Pump near these places. If you have to go through one of these devices, turn off your Momcozy Wearable Breast Pump. Before each usage, checking the status of your Momcozy Wearable Breast Pump to ensure it can operate normally.
- Using short-wave diathermy, microwave diathermy, or therapeutic ultrasound diathermy (all now referred to as diathermy) and electrocautery devices near this product may cause malfunction or lead to loss of performance, please do not use Momcozy Wearable Breast Pump near this equipment.

A list of cables and maximum length of cables is as follows:

Cables name	Cable length	Whether shielding
Charging cable	1000±10mm	No

Guidance and manufacture's declaration – electromagnetic emission

Emission test	Compliance	Electromagnetic environment – guidance
Conducted and Radiated RF emissions CISPR 11	Group 1 Class B	The Momcozy Wearable Breast Pump uses RF energy only for its internal function. Therefore, its RF emissions are very low and are not likely to cause any interference in nearby electronic equipment.
Conducted RF emissions CISPR 11	Group 1 Class B	The Momcozy Wearable Breast Pump is suitable for use in all establishments, including domestic and those directly connected to the public low-voltage power supply network that supplies buildings used for domestic purposes except for near active HF surgical equipment and the RF shielded room for magnetic resonance imaging.
Conducted RF emissions CISPR 11	Group 1 Class B	

Guidance and Manufacturer’s Declaration – Electromagnetic Immunity

The Momcozy Wearable Breast Pump is intended for use in the electromagnetic environment specified below. The customer or the user of the Momcozy Wearable Breast Pump should assure that it is used in such an environment

Guidance and Manufacturer’s Declaration – Electromagnetic Immunity			
The Momcozy Wearable Breast Pump is intended for use in the electromagnetic environment specified below. The customer or the user of the Momcozy Wearable Breast Pump should assure that it is used in such an environment.			
Immunity Test	IEC 60601-1-2 Test level	Compliance level	Electromagnetic environment-guidance
Electrostatic discharge IEC 61000-4-2	±8kV contact; ±2kV, ±4kV, ±8kV, ±15 kV air	±8kV contact; ±2kV, ±4kV, ±8kV, ±15kV air	Floors should be wood, concrete or ceramic tile. If floors are covered with synthetic material, the relative humidity should be at least 30%.

Radiated RF EM fields IEC 61000-4-3	10V/m (Home healthcare environment), 80MHz – 2.7GHz 80% AM at 1kHz	10V/m (Home healthcare environment) 80MHz – 2.7GHz 80% AM at 1kHz	
Electrical fast transients/bursts IEC 61000-4-4	±2kV AC power supply lines; ±1kV DC power/Signal lines. 100 kHz repetition frequency	±2kV AC power supply lines;	power quality should be that of a HOME HEALTHCARE ENVIRONMENT.
Surges IEC 61000-4-5	±0.5kV, ±1kV lines to lines; ±0.5kV, ±1kV, ±2kV lines to earth	±0.5kV, ±1kV lines to lines;	power quality should be that of a HOME HEALTHCARE ENVIRONMENT.
Conducted disturbances induced by RF fields IEC 61000-4-6	3V 0.15MHz – 80MHz, 6V in ISM bands between 0.15MHz and 80MHz 80% AM at 1kHz	3V 0.15MHz – 80MHz, 6V in ISM and amateur radio bands between 0.15MHz and 80MHz 80% AM at 1kHz	power quality should be that of a HOME HEALTHCARE ENVIRONMENT.

Note:

The ISM (industrial, scientific and medical) bands between 0,15 MHz and 80 MHz are 6,765 MHz to 6,795 MHz; 13,553 MHz to 13,567 MHz; 26,957 MHz to 27,283 MHz; and 40,66 MHz to 40,70 MHz. The amateur radio bands between 0,15 MHz and 80 MHz are 1,8 MHz to 2,0 MHz, 3,5 MHz to 4,0 MHz, 5,3 MHz to 5,4 MHz, 7 MHz to 7,3 MHz, 10,1 MHz to 10,15 MHz, 14 MHz to 14,2 MHz, 18,07 MHz to 18,17 MHz, 21,0 MHz to 21,4 MHz, 24,89 MHz to 24,99 MHz, 28,0 MHz to 29,7 MHz and 50,0 MHz to 54,0 MHz.

Rated power frequency magnetic fields IEC 61000-4-8	30A/m 50Hz or 60Hz	30A/m 50Hz	Power frequency magnetic fields should be at levels characteristic of a HOME HEALTHCARE ENVIRONMENT.
Voltage dips IEC 61000-4-11	0% U_T , 0,5 cycle At 0°, 45°, 90°, 135°, 180°, 225°, 270° and 315°; 0% U_T , 1 cycle and 70% U_T , 25/30 cycle Single phase: at 0°	Applicable	power quality should be that of a HOME HEALTHCARE ENVIRONMENT.
Voltage interruptions IEC 61000-4-11	0% U_T , 250/300 cycle	Applicable	
NOTE: U_T is the a.c. mains voltage prior to application of the test level. E.g.: 25/30 means 25 periods at 50 Hz or 30 periods at 60 Hz.			

Guidance and manufacture’s declaration – electromagnetic immunity

The Momcozy Wearable Breast Pump is intended for use in the electromagnetic environment specified below. The customer or the user of the Momcozy Wearable Breast Pump should assure that it is used in such an environment.

Immunity test	IEC 60601-1-2 test level	Compliance level	Electromagnetic environment - guidance
Proximity fields from RF wireless communications equipment IEC 61000-4-3	See the following table	Complies	
Proximity magnetic fields IEC 61000-4-39	See the following table	Complies	

Test specifications for ENCLOSURE PORT IMMUNITY to RF wireless communications equipment

Test frequency (MHz)	Band^{a)} (MHz)	Service^{a)}	Modulation	Immunity Test Level (V/m)
385	380 – 390	TETRA 400	Pulse modulation ^{b)} 18 Hz	27
450	430 – 470	GMRS 460, FRS 460	FM ^{c)} ± 5 kHz deviation 1 kHz sine	28
710	704 – 787	LTE Band 13, 17	Pulse modulation ^{b)} 217 Hz	9
745				
780				
810	800 – 960	GSM 800/900, TETRA 800, iDEN 820, CDMA 850, LTE Band 5	Pulse modulation ^{b)} 18 Hz	28
870				
930				
1720	1700 – 1990	GSM 1800; CDMA 1900; GSM 1900; DECT; LTE Band 1, 3, 4, 25; UMTS	Pulse modulation ^{b)} 217 Hz	28
1845				
1970				

2450	2400 – 2570	Bluetooth, WLAN, 802.11 b/g/n, RFID 2450, LTE Band 7	Pulse modulation ^{b)} 217 Hz	28
5240	5100 – 5800	WLAN 802.11 a/n	Pulse modulation ^{b)} 217 Hz	9
5500				
5785				
NOTE If necessary to achieve the IMMUNITY TEST LEVEL, the distance between the transmitting antenna and the MEEQUIPMENT or ME SYSTEM may be reduced to 1 m. The 1 m test distance is permitted by IEC 61000-4-3.				
a) For some services, only the uplink frequencies are included. b) The carrier shall be modulated using a 50 % duty cycle square wave signal. c) As an alternative to FM modulation, the carrier may be pulse modulated using a 50% duty cycle square wave signal at 18 Hz, While it does not represent actual modulation, it would be worst case.				

Test specifications for enclosure port immunity to proximity magnetic files

Test frequency	Modulation	Immunity test level (A/M)
30 kHz ^{a)}	CW	8
134.2 kHz	Pulse modulation ^{b)} 2.1 kHz	65 ^{c)}
13.56 MHz	Pulse modulation ^{b)} 50 kHz	7.5 ^{c)}
a) This test is applicable only to ME EQUIPMENT and ME SYSTEMS intended for use in the home healthcare environment. b) The carrier shall be modulated using a 50% duty cycle square wave signal. c) r.m.s, before modulation is applied.		

Travel or International Use Statement

Since the performance of the Momcozy Wearable Breast Pump may be affected by the external environment, in view of the uncertainty and instability of the travel environment, please do not use the device during travel or on the aircraft.

The Momcozy Wearable Breast Pump can be internationally used, but it must be used and stored in the environment specified in this user manual, and please make sure the input power of your power adapter is AC 100~240V 50/60 Hz and output power is DC 5V 1A, and please make sure you have a converter to convert to the proper voltage of the target country. To ensure that the Momcozy Wearable Breast Pump is not affected during carrying, please check the following items before use to ensure it can operate normally:

- Check the Momcozy Wearable Breast Pump to ensure that it is free from damage and Before each usage, check the status of your Momcozy Wearable Breast Pump to ensure it can operate normally. If there is any abnormality, please stop using it.